



art conservation

2915 Detroit Ave
Cleveland, OH 44113

P: 216.658.8700

www.ica-artconservation.org

Framing Easel Paintings Materials – Suppliers – Resources

Reverse of Properly Framed Painting, Backing Board, and Hanging Hardware

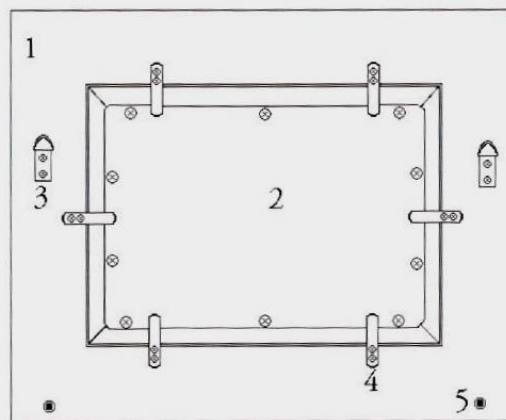

1. Back of a traditional picture frame
2. Backing board attached to stretcher with screws and washers
3. "D" rings to hang painting
4. Brass mending plates screwed into frame to secure the painting
5. Rubber spacers for air circulation

Credit: American Institute for Conservation of Historic and Artistic Works, Caring for Your Treasures: Paintings

Framing Supplies for Easel Paintings

Tape for lining frame rabbets:

CR Laurence Black 1" Wide Moleskin Channel Liner (synthetic fabric with a pressure sensitive adhesive on one side; the 1" width divides into 1/4" wide strips)

Framing Hardware – Mending plates and offset clips (aka z-clips)

Brass coated steel mending plates
Galvanized steel offset clips

Hanging Hardware – picture wire, d-rings, wall hooks

Plastic coated, stainless picture wire
Zinc plated steel d-rings

Monofilament for securing stretcher keys

Backing boards:

4 mm Coroplast® -natural color (corrugated virgin polypropylene backing board)

To attach the backing board, the ICA uses #8 x 1/2" Phillips head lath screws (aka washer screws). You can also use a washer and screw system.

The purpose of either system is to keep the screw from going through your board.

Glazing:

Acrylite® OP-3, Plexiglas® UF 5, or Tru-Vue Optium® (UV-filtered acrylic glazing)
Tru-Vue Optium has many options for non-reflective and scratch resistant acrylic glazing

Guidelines for choosing thickness of acrylic glazing:

Shortest dimension up to 40" – 1/8"

Shortest dimension between 40" x 60" – 3/16"

Shortest dimension above 60" – 1/4"

These guidelines assume standard proportions. If you have a painting that is 40" x 84", you'll want thicker glazing than 1/8".

Tru-Vue Conservation Clear® (UV-filtered glass glazing) or Museum Glass® (UV-filtered and non-reflective)

Supplies for Caring for Frames

Soft brushes:

Badger hair brushes (i.e. Badger blenders used by oil painters)
Goat hair brushes (i.e. Hake brushes used by watercolor painters)

High Density Sponges:

Qosmedix Sponges (latex free, polyurethane cosmetic sponges)

Watercolors:

Winsor and Newton half pans
Schmincke half pans

Suppliers – Easel Paintings

Dick Blick Art Materials, 800/828-4548, <http://www.dickblick.com/>

Watercolors, small brushes of inpainting, and wide, soft brushes for dusting

LeWinter Moulding, 800/633-8886, <http://www.lewintermoulding.com/index2.html>

Framing and hanging hardware

Museums Services Corp,

Framing and hanging hardware

Newegg, <http://www.newegg.com/>

CR Laurence felt tape for lining frame rabbets

Qosmedix, 631/242-3270, <http://www.qosmedix.com>

Sponges

Also available in small quantities at drug stores

Peregrine (267) 888-6657, <http://brushesandtools.com/>

Soft dusting brushes

Small Corp., 800/392-9500, www.smallcorp.com

Display and storage for works of art, textiles, and objects

Wholesale supplier

Fluted polypropylene sheets manufactured to very high standards, available in 4, 6, and 8mm

Talas, 212/219-0770, www.talasonline.com

Mending plates

United Mfrs. Supplies, Inc., 800/645-7260, <http://www.unitedmfrscatalog.com/home/index.htm>

Framing and hanging hardware

University Products, 800/628-1912, www.universityproducts.com

Benchmark felt tape for lining frame rabbets

Plastics and sign makers suppliers have Coroplast

Additional Resources and Websites

Hugh Glover. 2006. A description of 19th-century American gilded picture frames and an outline of their modern use and conservation. *2006 WAG Postprints*—Providence, Rhode Island:

http://cool.conservation-us.org/coolaic/sg/wag/2006/glover_06.pdf

D. Gene Karraker. 2009. *Looking at European Frames: A Guide to Terms, Styles, and Techniques*. Los Angeles: J. Paul Getty Museum.

American Institute for Conservation (AIC):

AIC Wiki, Paintings Specialty Group, Paintings Conservation Catalog, Stretchers and Strainers, IV Treatment Variations, Securing Stretcher Keys:

http://www.conservation-wiki.com/wiki/PSG_Stretchers_and_Strainers_-_IV_Treatment_Variations#K._SECURING_STRETCHER_KEYS

AIC Wiki, Paintings Specialty Group, Paintings Conservation Catalog, Stretchers and Strainers, IV Treatment Variations, Backing Boards:

http://www.conservation-wiki.com/wiki/PSG_Stretchers_and_Strainers_-_IV_Treatment_Variations#N._BACKING_BOARDS

Canadian Conservation Institute (CCI), CCI Notes (PDFs):

Framing a Painting, 10/8, 1993:

http://canada.pch.gc.ca/DAMAssetPub/DAM-PCH2-Museology-PreservConserv/STAGING/texte-text/10-8_1439925170508_eng.pdf?WT.contentAuthority=4.4.10

Smithsonian Museum Conservation Institute, Guidelines Pamphlets:

Caring for Your Paintings:

https://www.si.edu/mci/english/learn_more/taking_care/care_painting.html

Care of Acrylic Paintings:

https://www.si.edu/mci/english/learn_more/taking_care/acrylic_paintings.html